

YAMAHA V-STAR 1100 REAR AXLE BRACKETS INSTALLED

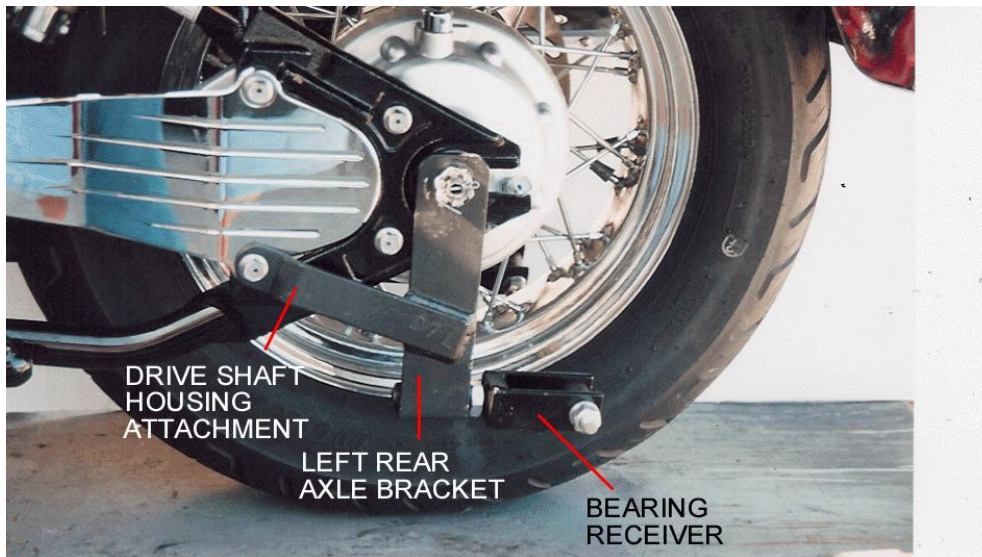

YAMAHA V-STAR 1100 BELLY BRACKET INSTALLED

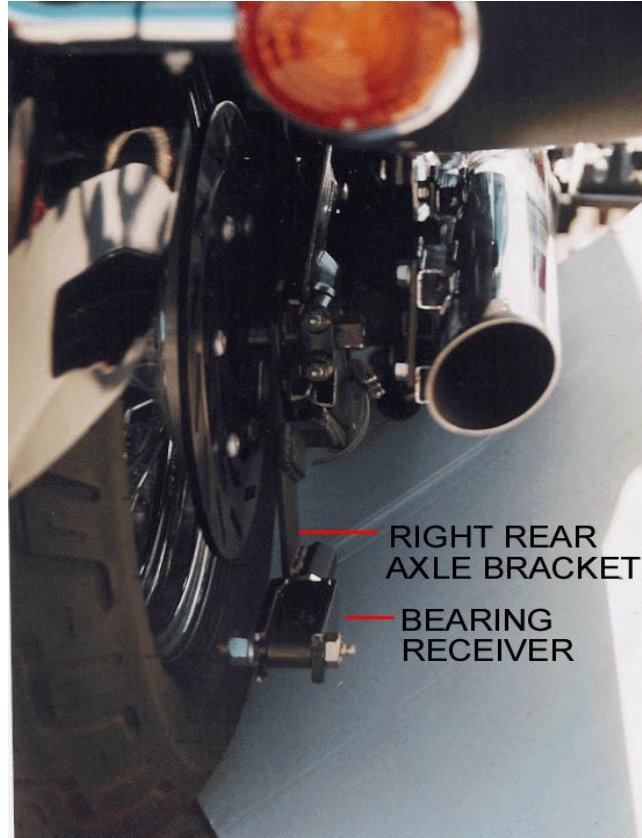
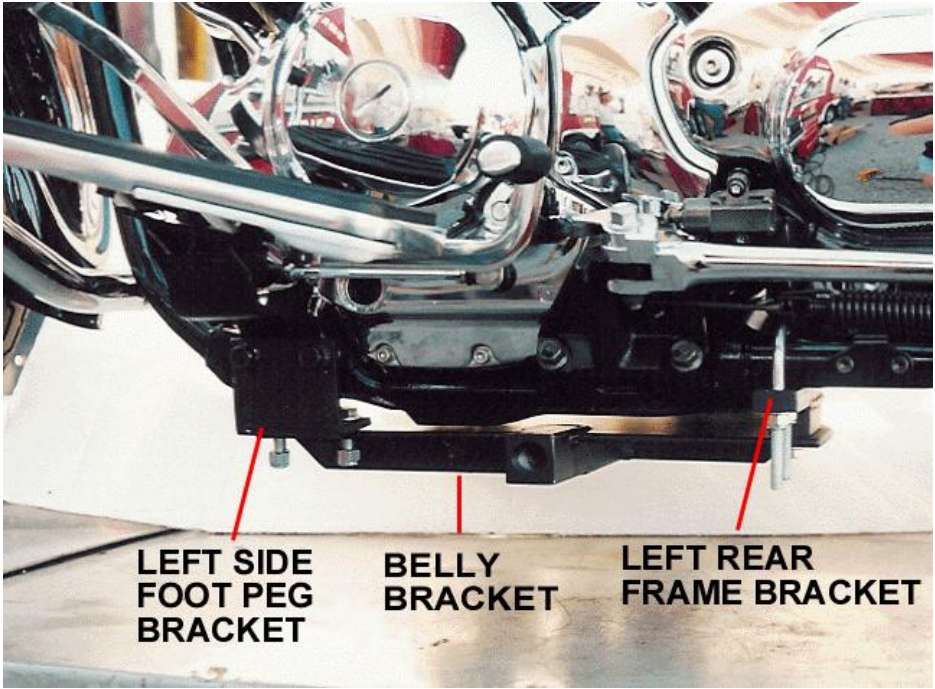
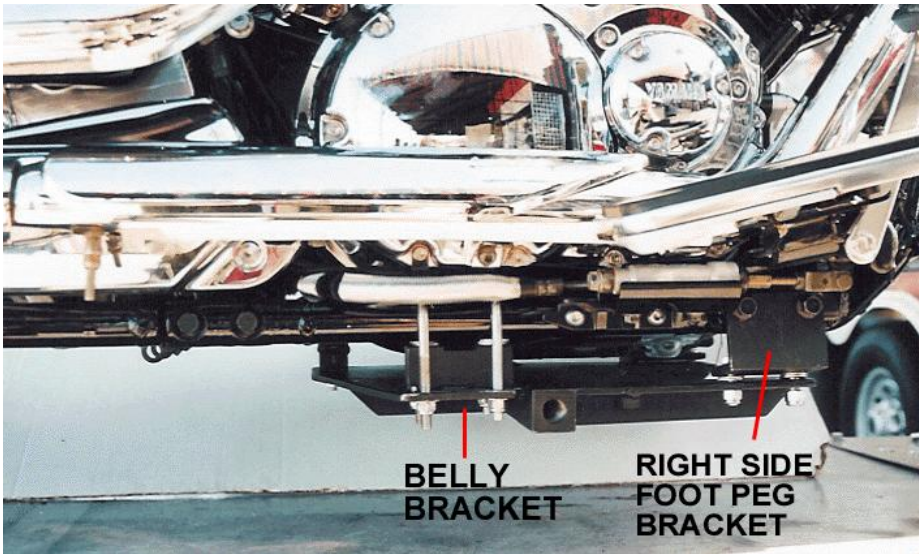

YAMAHA V-STAR 1100

DESCRIPTION OF PARTS

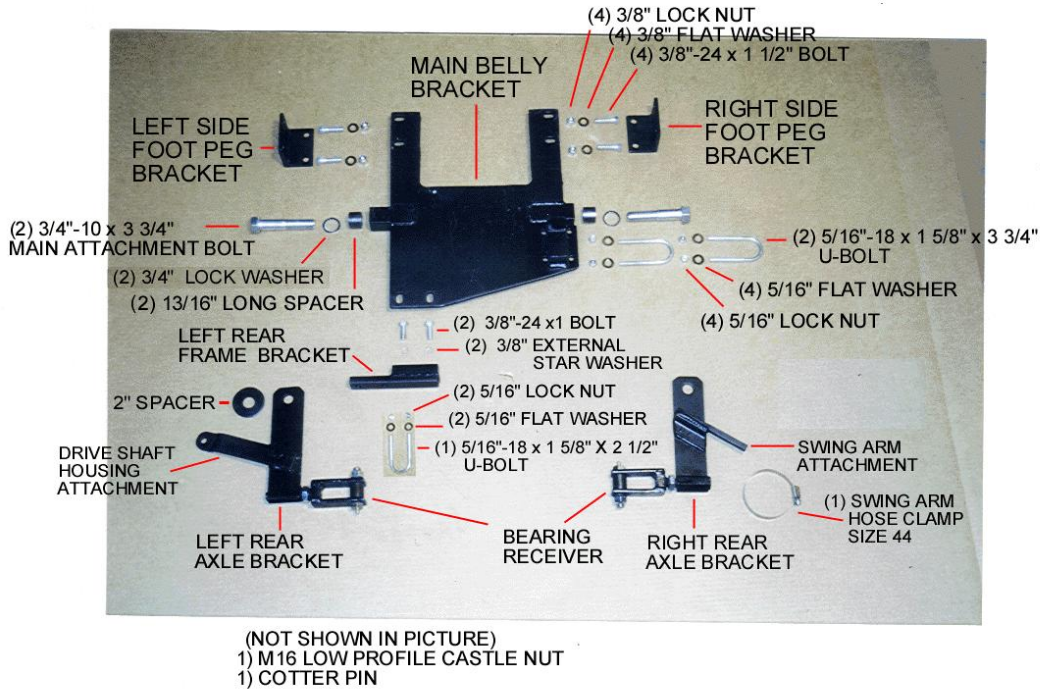

Two 3/8" washers used as shims and One 3" shim– not shown in picture above.
 You may or may not have to use the shims. See note below.

After installing the mounting hardware and attaching the Voyager frame to the belly bracket you may need shims to make the motorcycle stand straight up and down.

Right side only
 Place 3/8" shims in-between belly bracket and right side foot peg bracket.

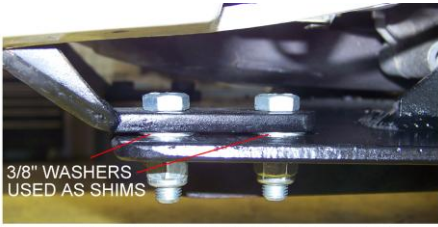

ILLUSTRATION OF SHIM PLACEMENT
 BRACKET PICTURED MAY NOT MATCH YOUR BRACKET

Place 3" shim in-between belly bracket rear tab and motorcycle frame.

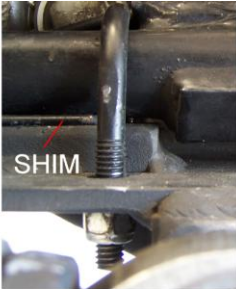

ILLUSTRATION OF SHIM PLACEMENT
 BRACKET PICTURED MAY NOT MATCH YOUR BRACKET

SECTION 1

INSTALLATION OF YAMAHA V-STAR 1100

MOUNTING HARDWARE

Place motorcycle on a clean flat surface. Be sure to tie down motorcycle so it does not tip over during installation. Installation is easier if motorcycle is in an upright position.

Disconnect negative cable from battery before beginning installation.

NOTE: The Voyager Convertible Kit was designed for a stock motorcycle from the manufacturer. Any after market products that are on a stock motorcycle may cause the installation process to not be done properly and may or may not need to be removed to be able to install the Voyager Convertible Kit completely. Be aware that your motorcycle and the same make & model as someone else's motorcycle may not have mufflers, body panels, frames, fenders and any other manufacturer parts that are attached to the motorcycle in the exact same place as yours. We at Motorcycle Tour Conversion, Inc. take that into consideration when we manufacture our parts to fit your motorcycle. Once in awhile you may need to modify your motorcycle slightly so that the Motorcycle Tour Conversion, Inc. hardware or suspension fits your motorcycle. Please call Motorcycle Tour Conversion, Inc. if you have any questions about installation with after market products or any modification of motorcycle and/or Motorcycle Tour Conversion, Inc. hardware.

A) BELLY BRACKET

- 1) Find left side foot peg bracket and install using the (2) bolts of the left side floor board of the motorcycle. Tighten all bolts at this time.
- 2) Find the right side foot peg bracket and install using the (2) bolts of the right side floor board of the motorcycle. Tighten bolts at this time.
- 3) Find the left rear frame bracket and attach it to the main belly bracket with (2) two 3/8"-24 -1" bolts and (2) 3/8" star washers provided with the kit.
- 4) Install the main belly bracket under the left and right foot peg brackets using (4) 3/8"- 24- 1 1/2" bolts and 3/8" washers and 3/8" lock nuts provided with the kit.

SECTION 1

INSTALLATION OF YAMAHA V-STAR 1100 MOUNTING HARDWARE

- 5) Install the (2) U-bolts 5/16" - 3 3/4 over the frame on the right side. Install the (1) U-bolt 5/16" - 2 1/2 over the frame on the left side of the motorcycle.
- 6) Hold main belly bracket up to the frame and install the U-bolts on both sides with washers and nuts. Tighten all belly bracket bolts and nuts at this time.

B) REAR AXLE BRACKETS

- 1) Remove axle nut on left side. On the right side remove the (2) bolts and cup that hold the axle bolt. At this time remove the axle bolt.
- 2) Find the right rear axle bracket. It will fit on the inside of the motorcycle's swing arm. Install the axle bolt through the hole of the motorcycle then through right rear axle bracket. Push the axle bolt all the way through the motorcycle. Attach rear axle bracket to swing arm of motorcycle with hose clamp.
- 3) Remove the lower bolt from the drive shaft housing. Install the 2" left rear axle bracket spacer over axle bolt. Install left rear axle bracket over the axle bolt and line up drive shaft housing attachment with hole on drive shaft housing of motorcycle.
- 4) Install axle nut using replacement axle nut provided with kit. You may have to drill new hole for cotter pin.



MOTORCYCLE TOUR CONVERSION, INC.
1530 TITANIUM DR
OTTAWA, IL. 61350

TOLL FREE: 877-434-7901
FAX: 815-434-8980

YAMAHA V-STAR 1100 CUSTOM, CLASSIC, SILVERADO

INSTALLATION MANUAL
US PATENT # 6,739,420

**WARRANTY WILL BE VOID IF INSTALLATION
IS NOT DONE PROPERLY**

**READ THIS MANUAL FULLY BEFORE
BEGINNING INSTALLATION OR DRIVING YOUR
MOTORCYCLE WITH THE VOYAGER KIT ATTACHED**

