

YAMAHA V-STAR 950 REAR AXLE BRACKETS INSTALLED

LEFT REAR
AXLE BRACKET

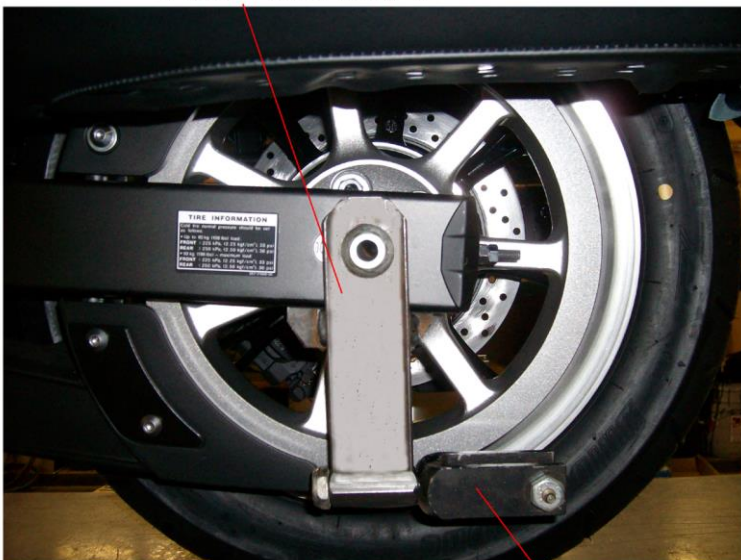

PICTURE FIVE

BEARING
RECEIVER

RIGHT REAR
AXLE BRACKET

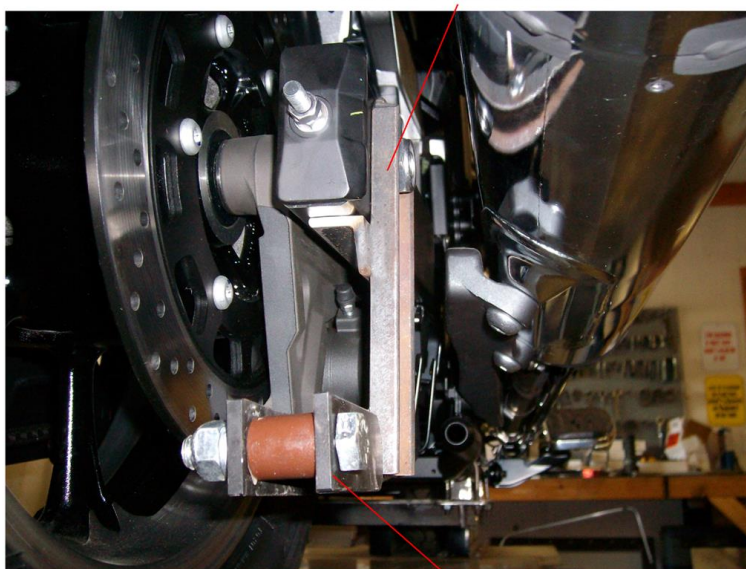

PICTURE SIX

BEARING
RECEIVER

YAMAHA V-STAR 950 BELLY BRACKET INSTALLED

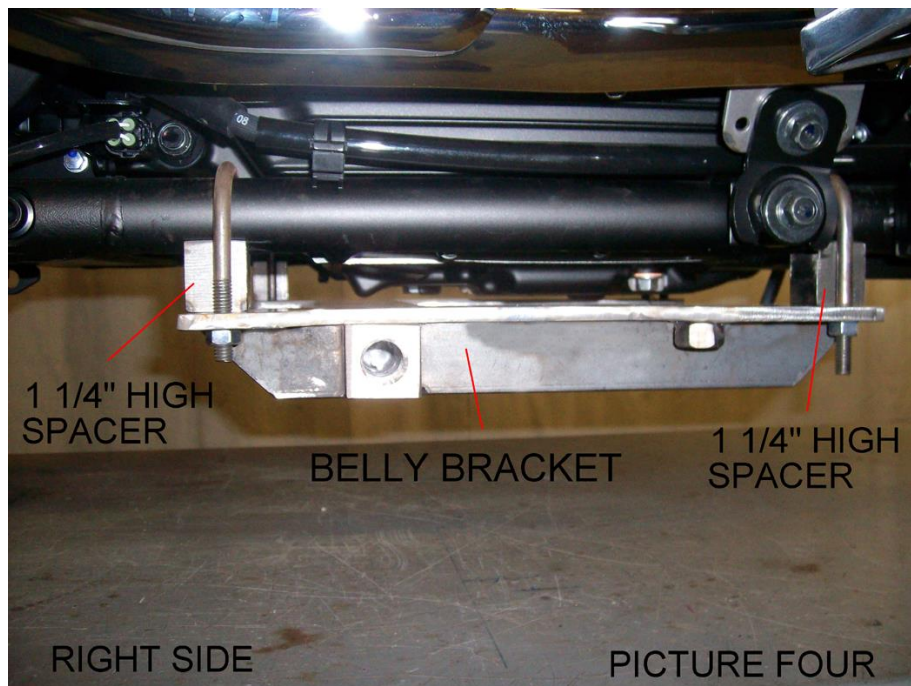
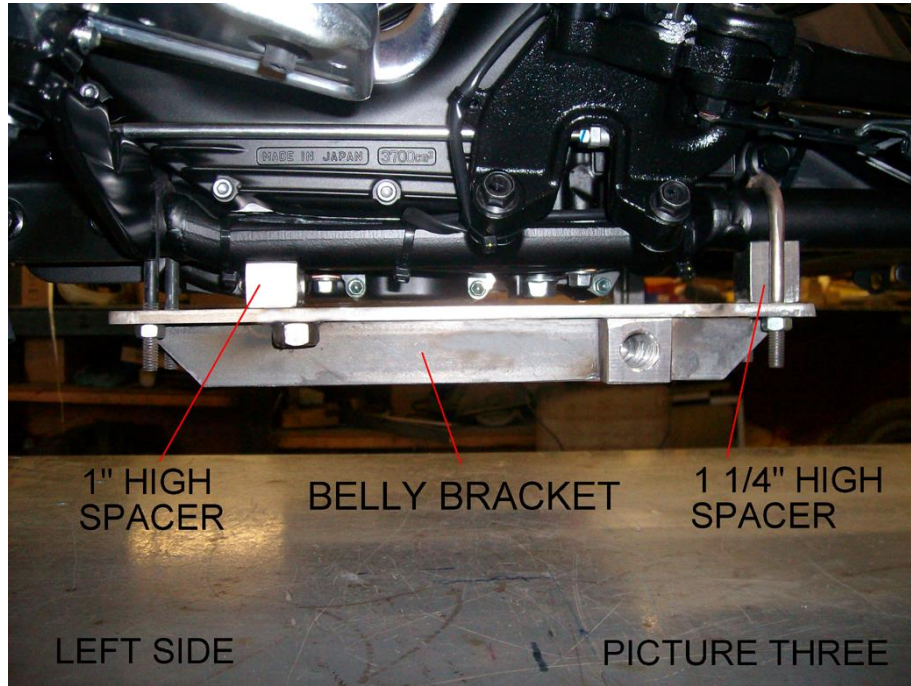

YAMAHA V-STAR 950 LEFT FORWARD U-BOLT INSTALLED

LEFT FORWARD
U-BOLT 5/16"-18 x 1 5/16" x 3"



PICTURE ONE

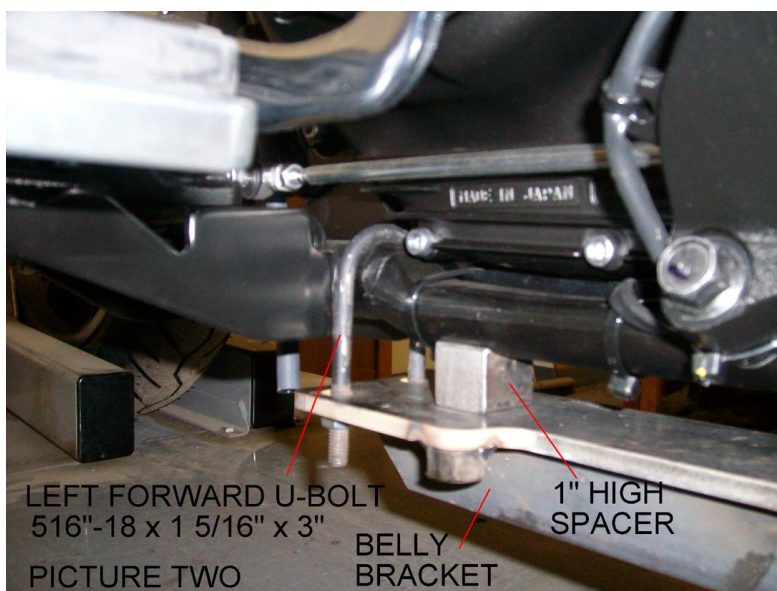

PICTURE TWO

YAMAHA V-STAR 950 DESCRIPTION OF PARTS

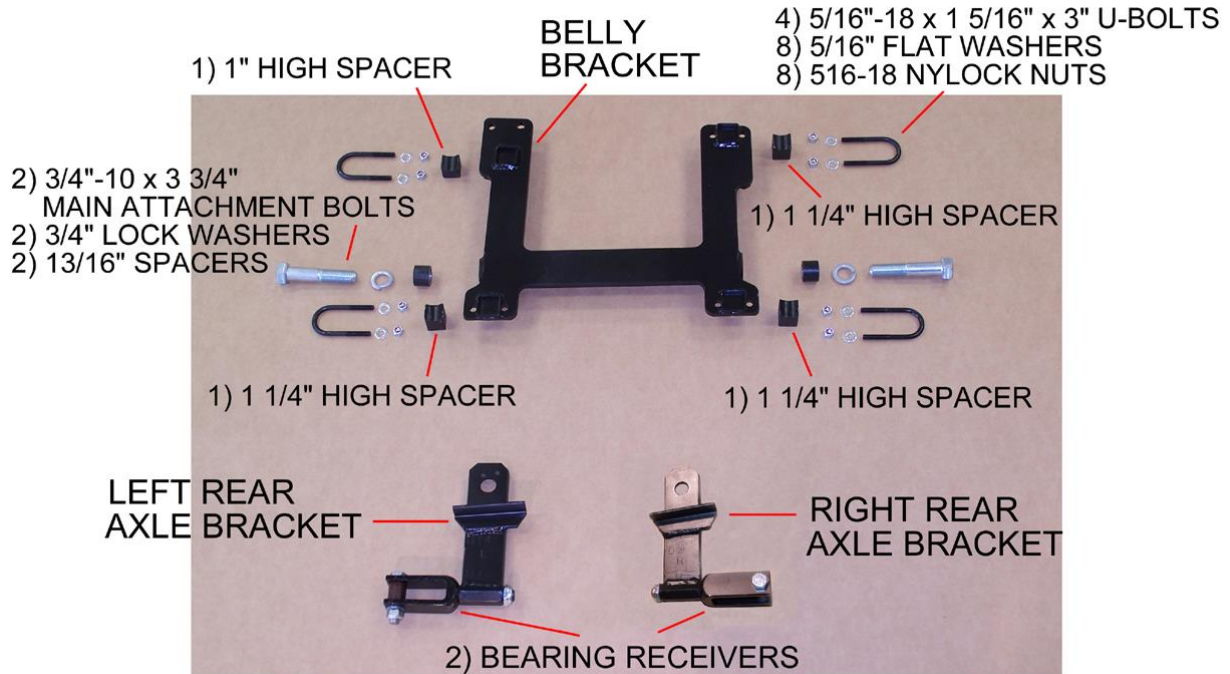

Two 2" shims– not shown in picture above.
You may or may not have to use the shims. See note below.

After installing the mounting hardware and attaching the Voyager frame to the belly bracket you may need shims to make the motorcycle stand straight up and down. The shims may be used on either the left or the right side depending on which way the motorcycle is leaning. If the motorcycle is leaning to the left put the shims on the left side. If the motorcycle is leaning to the right put the shims on the right side. The shims will go on the front and back of one side of the belly bracket.

Place shims in-between belly bracket tabs and motorcycle frame.

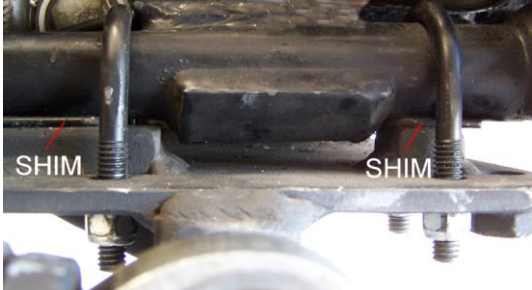

ILLUSTRATION OF SHIM PLACEMENT
 BRACKET PICTURED MAY NOT MATCH YOUR BRACKET

SECTION 1

INSTALLATION OF

YAMAHA V-STAR 950

MOUNTING HARDWARE

Place motorcycle on clean flat surface. Make sure your motorcycle is tied down on both sides. This prevents motorcycle from tipping over. Installation is easier if motorcycle is in an upright position. Lay out all hardware.

Disconnect negative cable from battery before beginning installation.

NOTE: The Voyager Convertible Kit was designed for a stock motorcycle from the manufacturer. Any after market products that are on a stock motorcycle may cause the installation process to not be done properly and may or may not need to be removed to be able to install the Voyager Convertible Kit completely. Be aware that your motorcycle and the same make & model as someone else's motorcycle may not have mufflers, body panels, frames, fenders and any other manufacturer parts that are attached to the motorcycle in the exact same place as yours. We at Motorcycle Tour Conversion, Inc. take that into consideration when we manufacture our parts to fit your motorcycle. Once in awhile you may need to modify your motorcycle slightly so that the Motorcycle Tour Conversion, Inc. hardware or suspension fits your motorcycle. Please call Motorcycle Tour Conversion, Inc. if you have any questions about installation with after market products or any modification of motorcycle and/or Motorcycle Tour Conversion, Inc. hardware.

A) BELLY BRACKET

Note: Placement of belly bracket is determined by placement of left side forward u-bolt. Also the belly bracket has (1) 1" and (3) 1 1/4" spacers that have to be installed.

- 1) Install left side forward u-bolt 5/16"-18 x 1 5/16" x 3" over motorcycle frame (Shown in picture one & two)
- 2) Install left side rear u-bolt 5/16"-18 x 1 5/16" x 3" over motorcycle frame behind side stand rear mounting bolt. (Shown in picture three)
- 3) Install left side of belly bracket to u-bolts with (4) 5/16" flat washers and (4) 5/16-18 nylock nuts. Before snugging nylock nuts, install into left side of belly bracket (1) 1" spacer and (1) 1 1/4" spacer. Then snug nylock nuts. **(Don't tighten completely at this time)** (Shown in picture three)
- 4) Install (2) u-bolts 5/16"-18 x 1 5/16" x 3" over right side of motorcycle frame. (Shown in picture four)

SECTION 1

INSTALLATION OF YAMAHA V-STAR 950 MOUNTING HARDWARE

- 5) Install right side of belly bracket to u-bolts with (4) 5/16" flat washers and (4) 5/16"-18 nylock nuts. Before snugging nylock nuts, install (2) 1 1/4" spacers into right side of belly bracket. Then snug nylock nuts. **(Don't tighten completely at this time.)** (Shown in picture four)

(Note: You will tighten belly bracket completely after Voyager frame is installed and lined up.)

B) REAR AXLE BRACKETS

LEFT REAR AXLE BRACKET

- 1) Remove axle nut and washer, then remove axle bolt and washer. Note: When axle bolt is removed there are two factory washers, one on each side. You will not use the two factory washers.
- 2) Install left rear axle bracket over axle bolt. Then install axle bolt. (Shown in picture five.)

RIGHT REAR AXLE BRACKET

- 1) Install right rear axle bracket over axle bolt and install factory axle nut. Tighten axle nut at this time. (Shown in pictures six)



MOTORCYCLE TOUR CONVERSION, INC.
1530 TITANIUM DR.
OTTAWA, IL. 61350

TOLL FREE: 877-434-7901
FAX: 815-434-8980

YAMAHA V-STAR 950 (2009-)

INSTALLATION MANUAL
US PATENT # 6,739,420

**WARRANTY WILL BE VOID IF INSTALLATION
IS NOT DONE PROPERLY**

**READ THIS MANUAL FULLY BEFORE
BEGINNING INSTALLATION OR DRIVING YOUR
MOTORCYCLE WITH THE VOYAGER KIT ATTACHED**