

# HONDA CB 500

## REAR AXLE BRACKETS INSTALLED

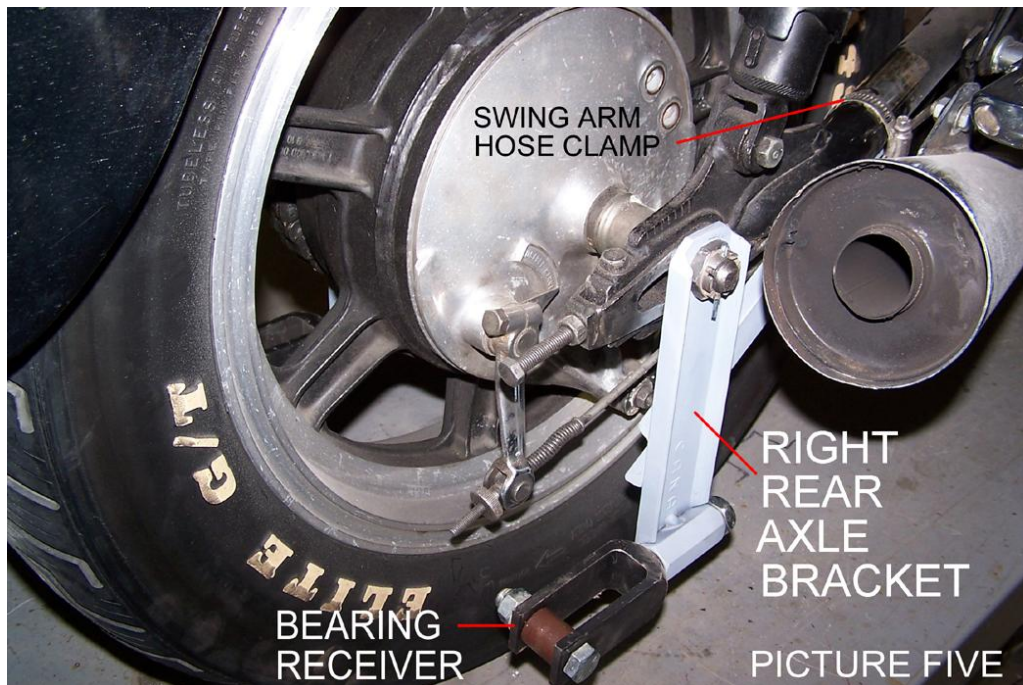

**HONDA CB 500  
BELLY BRACKET INSTALLED  
(PICTURES ONE & TWO & THREE)**

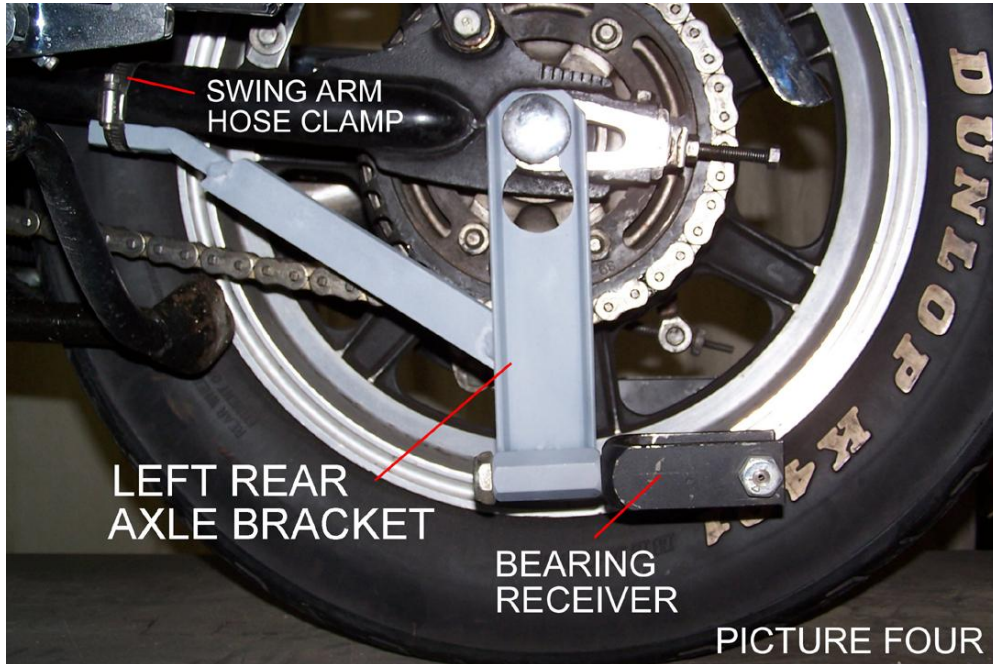
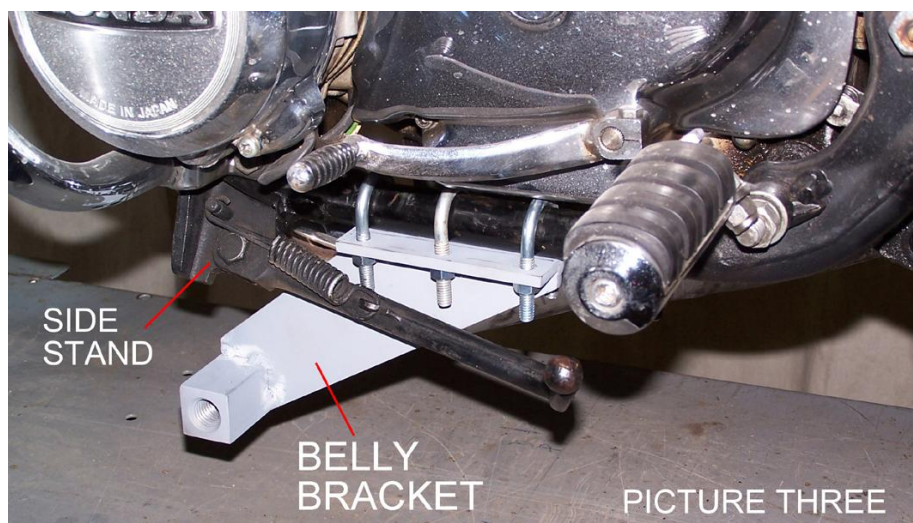
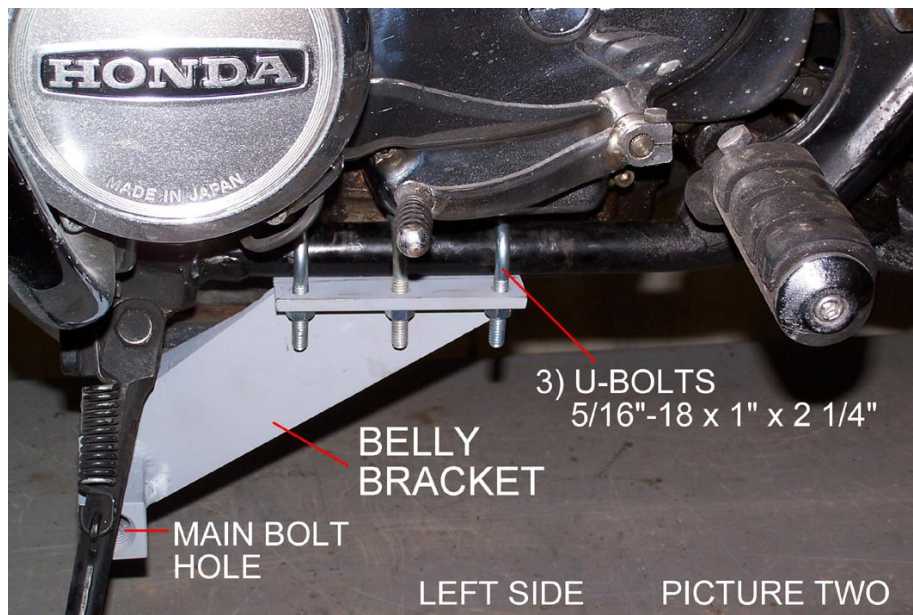
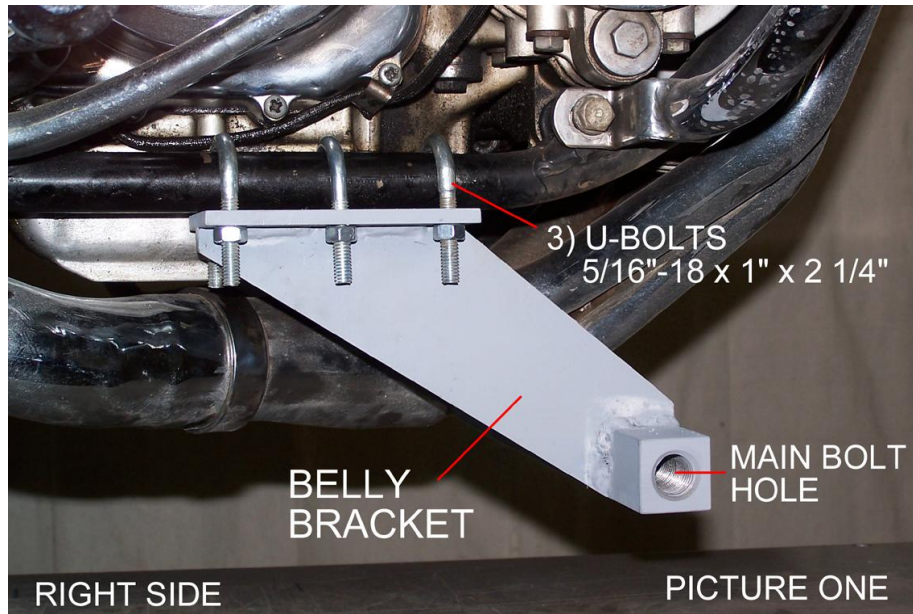

# HONDA CB 500

## DESCRIPTION OF PARTS

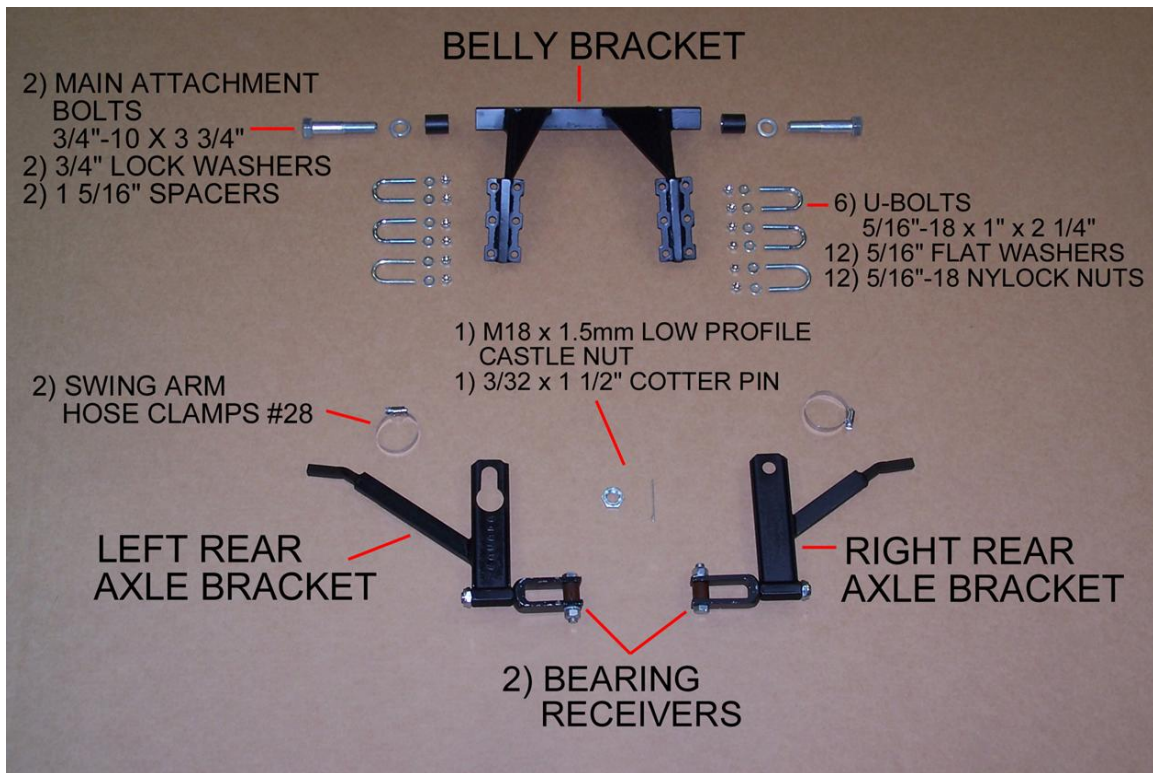

One 4 1/2" shim – not shown in picture above.

You may or may not have to use the shim. See note below.

After installing the mounting hardware and attaching the Voyager frame to the belly bracket you may need a shim to make the motorcycle stand straight up and down. The shim may be used on either the left or the right side depending on which way the motorcycle is leaning. If the motorcycle is leaning to the left put the shim on the left side. If the motorcycle is leaning to the right put the shim on the right side. The shim will go on one side of the belly bracket.

**Install the shim in-between belly bracket and motorcycle frame.**

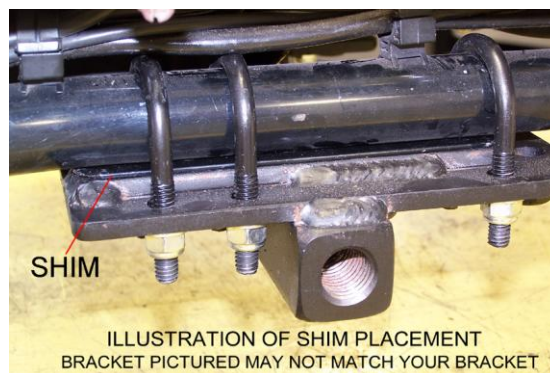

# SECTION 1

## INSTALLATION OF HONDA CB 500

(For motorcycle with 4 to 1 pipes on the right side)

### MOUNTING HARDWARE

Place motorcycle on a clean flat surface. Be sure to tie down motorcycle so it does not tip over during installation. Installation is easier if motorcycle is in an upright position.

**Disconnect negative cable from battery before beginning installation.**

**NOTE:** The Voyager Convertible Kit was designed for a stock motorcycle from the manufacturer. Any after market products that are on a stock motorcycle may cause the installation process to not be done properly and may or may not need to be removed to be able to install the Voyager Convertible Kit completely. Be aware that your motorcycle and the same make & model as someone else's motorcycle may not have mufflers, body panels, frames, fenders and any other manufacturer parts that are attached to the motorcycle in the exact same place as yours. We at Motorcycle Tour Conversion, Inc. take that into consideration when we manufacture our parts to fit your motorcycle. Once in awhile you may need to modify your motorcycle slightly so that the Motorcycle Tour Conversion, Inc. hardware or suspension fits your motorcycle. Please call Motorcycle Tour Conversion, Inc. if you have any questions about installation with after market products or any modification of motorcycle and/or Motorcycle Tour Conversion, Inc. hardware.

#### A) BELLY BRACKET

- 1) Install 3) u-bolts 5/16"-18 x 1" x 2 1/4" over right side of motorcycle frame.  
(Shown in picture one)
- 2) Install 3) u-bolts 5/16"-18 x 1" x 2 1/4" over left side of motorcycle frame.  
(Shown in picture two)
- 3) Attach belly bracket to the u-bolts with 12) 5/16" flat washers, and 12) 5/16"-18 nylock nuts.
- 4) Measure from center of main bolt hole back to center of motorcycle axle bolt. Measurement should be about 32 inches. This will be the correct position of belly bracket. At this time snug belly bracket. **After installing Voyager frame tighten all u-bolts completely.** (Shown in pictures one & two)
- 5) **Picture three** – you can see side stand of motorcycle is up as far as it will go. This will be fine.

**SECTION 1**  
**INSTALLATION OF HONDA CB 500**  
**(For motorcycle with 4 to 1 pipes on the right side)**  
**MOUNTING HARDWARE**

**B) REAR AXLE BRACKETS**

**LEFT REAR AXLE BRACKET**

- 1) Remove factory axle nut and tap out axle bolt about 1/2".
- 2) Install the left rear axle bracket over axle bolt, then tap axle bolt back in.
- 3) Attach swing arm attachment of axle bracket to the swing arm of motorcycle with hose clamp provided with kit.  
**(Shown in picture four)**

**RIGHT REAR AXLE BRACKET**

- 1) Install right rear axle bracket over axle bolt. Install M18 x 1.5mm low profile castle nut provided with kit. (Do not tighten at this time)
- 2) Attach swing arm attachment of right rear axle bracket to swing arm of motorcycle with hose clamp provided with kit.
- 3) Tighten castle nut and install 1) 3/32" x 1 1/2" cotter pin provided with kit.  
**(Shown in picture five)**



MOTORCYCLE TOUR CONVERSION, INC.  
1530 TITANIUM DRIVE  
OTTAWA, IL 61350

TOLL FREE: 877-434-7901  
FAX: 815-434-8980

## **HONDA CB 500**

(For motorcycle with 4 to 1 pipes on right side)



INSTALLATION MANUAL  
US PATENT # 6,739,420

**WARRANTY WILL BE VOID IF INSTALLATION  
IS NOT DONE PROPERLY**

**READ THIS MANUAL FULLY BEFORE  
BEGINNING INSTALLATION OR DRIVING YOUR  
MOTORCYCLE WITH THE VOYAGER KIT ATTACHED**

