

# HONDAMATIC 750 REAR AXLE BRACKETS INSTALLED

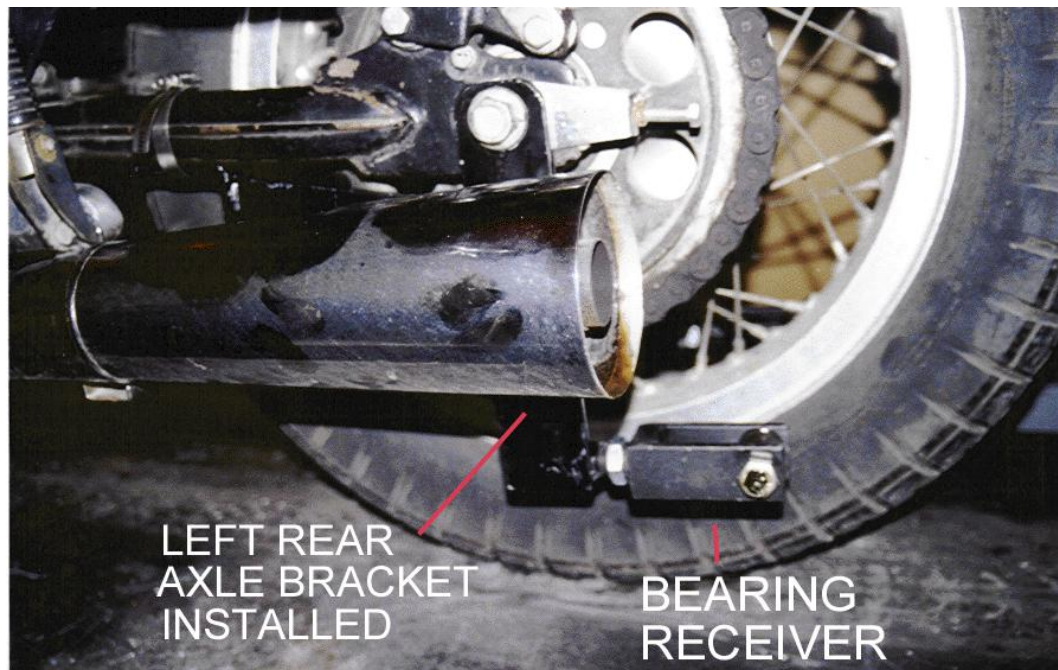

## HONDAMATIC 750 BELLY BRACKET INSTALLED (part 2)

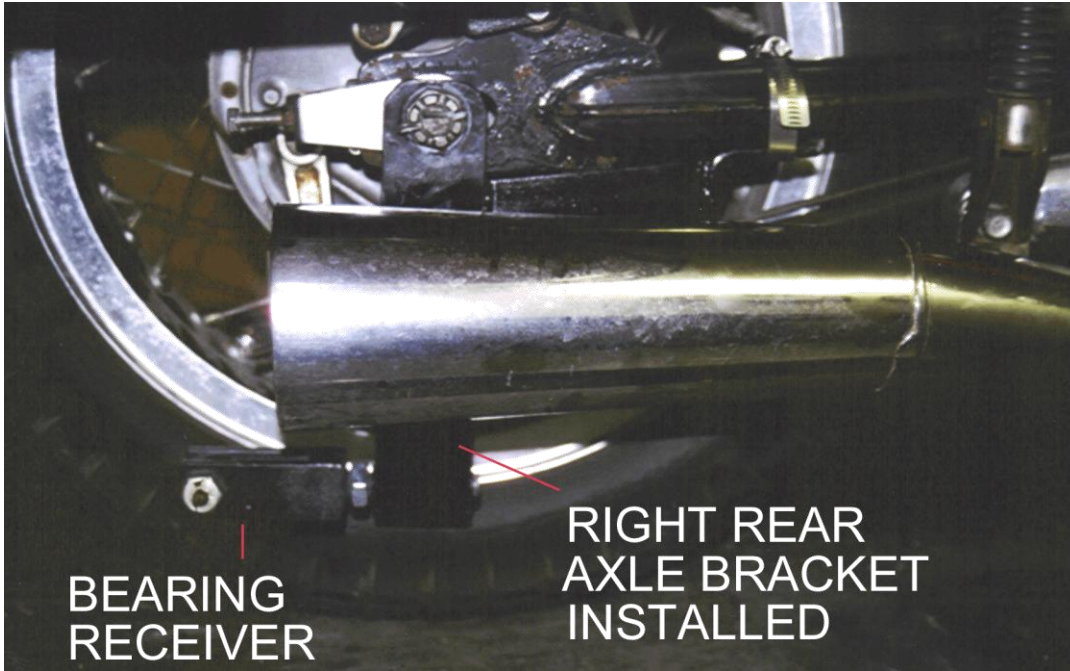

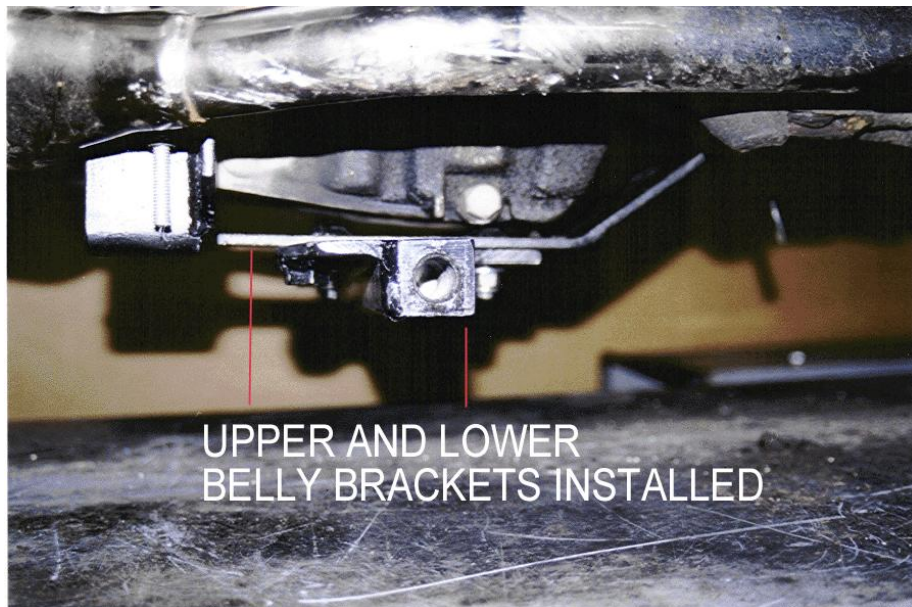
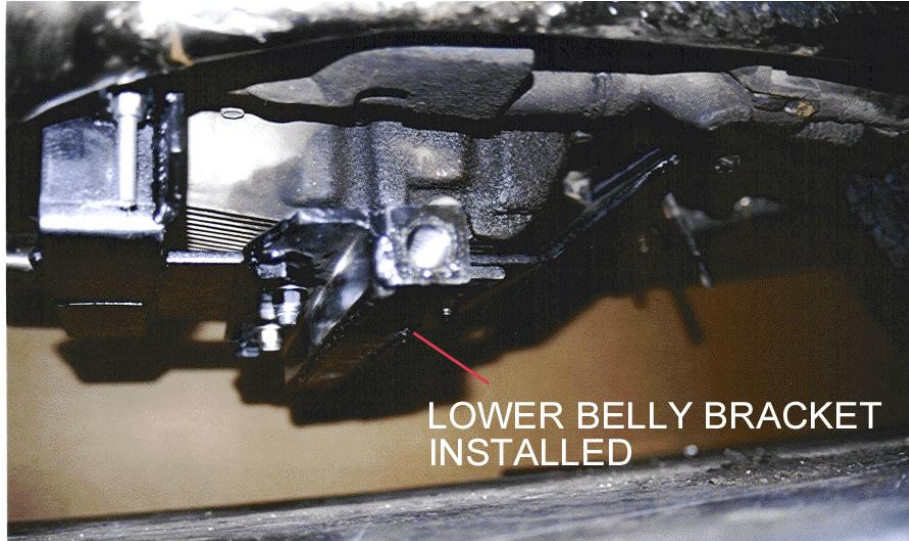

# HONDAMATIC 750 BELLY BRACKET INSTALLED (part 1)

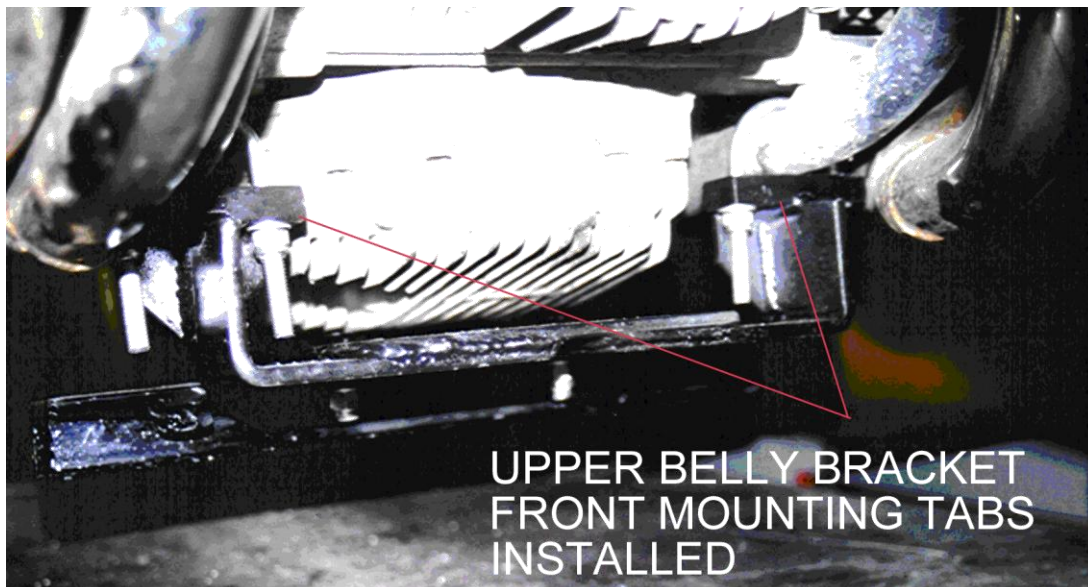
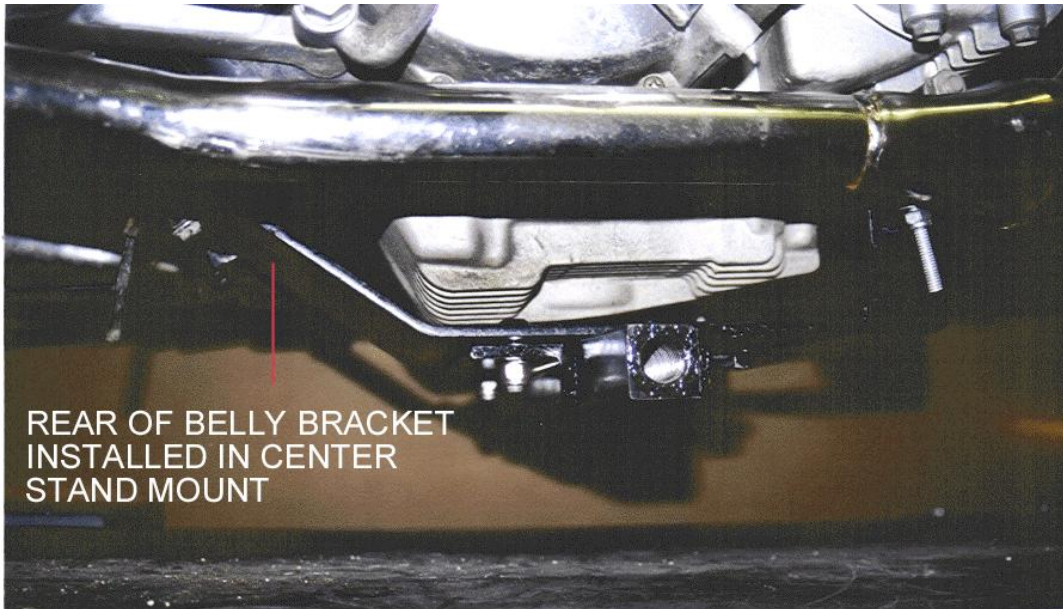

# HONDA MATIC 750

## DESCRIPTION OF PARTS

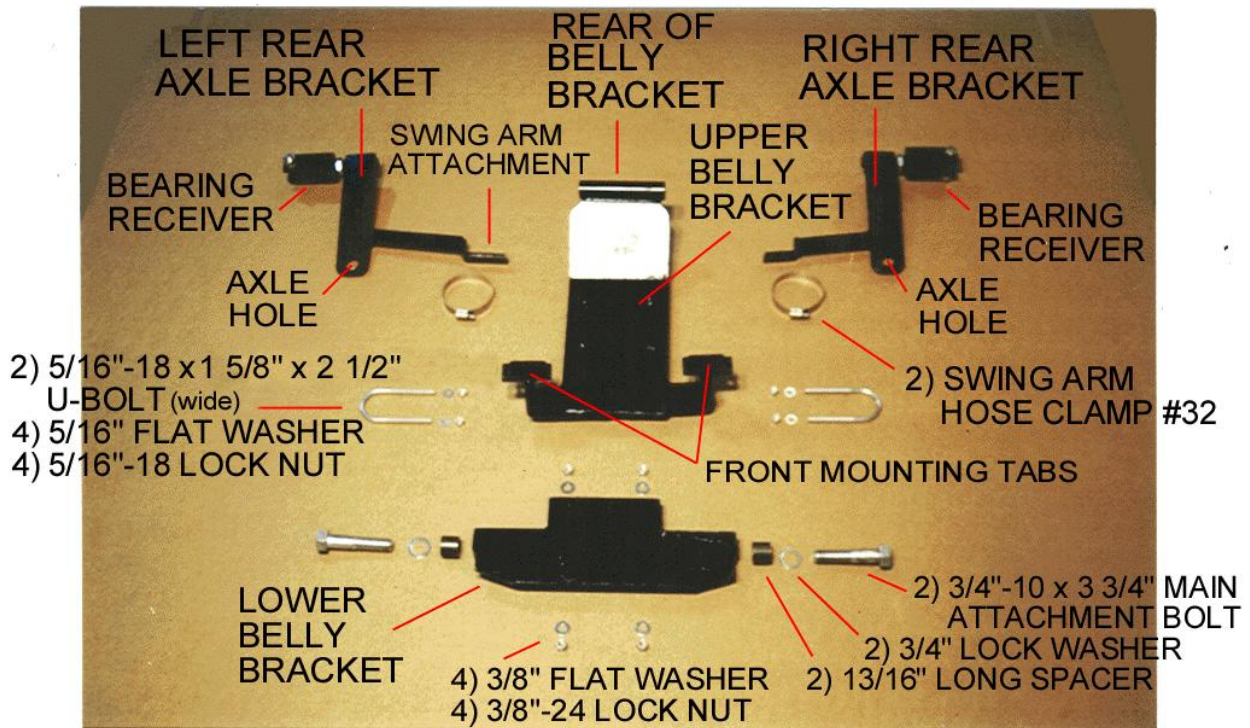

Two 3/8" washers used as shims– not shown in picture above.  
 You may or may not have to use the shims. See note below.

After installing the mounting hardware and attaching the Voyager frame to the belly bracket you may need shims to make the motorcycle stand straight up and down. The shims may be used on either the left or the right side depending on which way the motorcycle is leaning. If the motorcycle is leaning to the left put the shims on the left side. If the motorcycle is leaning to the right put the shims on the right side.

**Place shims over 3/8" holes on top of lower belly bracket. Shims may be used on either the left or right side depending on which way bike is leaning. Install lower belly bracket to upper belly bracket.**

**HONDA MATIC 750**  
**DESCRIPTION OF PARTS**

# SECTION 1

## INSTALLATION OF HONDAMATIC 750

### MOUNTING HARDWARE

Place motorcycle on a clean flat surface. Be sure to tie down motorcycle so it does not tip over during installation of Voyager hardware. Installation is easier if motorcycle is in an upright position.

**Disconnect negative cable from battery before beginning installation.**

**NOTE:** The Voyager Convertible Kit was designed for a stock motorcycle from the manufacturer. Any after market products that are on a stock motorcycle may cause the installation process to not be done properly and may or may not need to be removed to be able to install the Voyager Convertible Kit completely. Be aware that your motorcycle and the same make & model as someone else's motorcycle may not have mufflers, body panels, frames, fenders and any other manufacturer parts that are attached to the motorcycle in the exact same place as yours. We at Motorcycle Tour Conversion, Inc. take that into consideration when we manufacture our parts to fit your motorcycle. Once in awhile you may need to modify your motorcycle slightly so that the Motorcycle Tour Conversion, Inc. hardware or suspension fits your motorcycle. Please call Motorcycle Tour Conversion, Inc. if you have any questions about installation with after market products or any modification of motorcycle and/or Motorcycle Tour Conversion, Inc. hardware.

#### A) BELLY BRACKET

- 1) Remove the center kickstand from motorcycle.
- 2) Install the rear of the upper belly bracket to the center kickstand mounting brackets.
- 3) Tilt the belly bracket up and "U" bolt front mounting tabs to motorcycle frame.
- 4) Install the lower belly bracket to the upper belly bracket using 4) 3/8" flat washers and lock nuts provided with kit.

#### B) REAR AXLE BRACKETS

- 1) Remove the rear axle and attach the rear axle brackets by inserting the axle through the holes in the axle brackets.
- 2) Using the hose clamps provided with this kit, clamp the front swing arm attachments of the axle brackets to the swing arms.





MOTORCYCLE TOUR CONVERSION, INC.  
1530 TITANIUM DRIVE  
OTTAWA, IL 61350

TOLL FREE: 877-434-7901  
FAX: 815-434-8980

## HONDAMATIC 750



INSTALLATION MANUAL  
US PATENT # 6,739,420

**WARRANTY WILL BE VOID IF INSTALLATION  
IS NOT DONE PROPERLY**

**READ THIS MANUAL FULLY BEFORE  
BEGINNING INSTALLATION OR DRIVING YOUR  
MOTORCYCLE WITH THE VOYAGER KIT ATTACHED**

